



CH 08 - PRESTAZIONI CON MOTORI A 4 POLI 1400 GIRI ENTRATA

TIPO	i=ratio	n2 r/min	Kw=P1	Nm=T2	f.s.	Pred. attacco motore possibili	
CH 08	7	200	4	170	1.5	112/100/90	B5/B14
	10	140	4	240	1.2	112/100/90	B5/B14
	15	93	4	350	0.9	112/100/90	B5/B14
	20	70	3.00	340	0.9	100/90	B5/B14
	23	61	2.20	280	1.1	100/90	B5/B14
	30	47	2.20	340	1.1	100/90	B5/B14
	40	35	1.85	340	0.9	90/80	B5/B14
	46	30	1.5	340	1.0	90/80	B5/B14
	56	25	1.1	290	1.0	90/80	B5/B14
	64	22	1.1	290	0.9	90/80	B5/B14
	80	17	0.75	260	1.0	90/80	B5/B14
	100	14	0.55	220	1.0	80	B5/B14

Peso Kg 12,2

DIMENSIONI

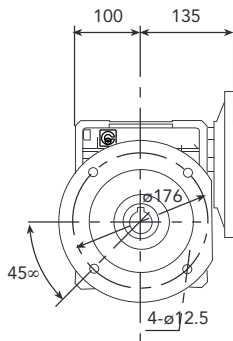
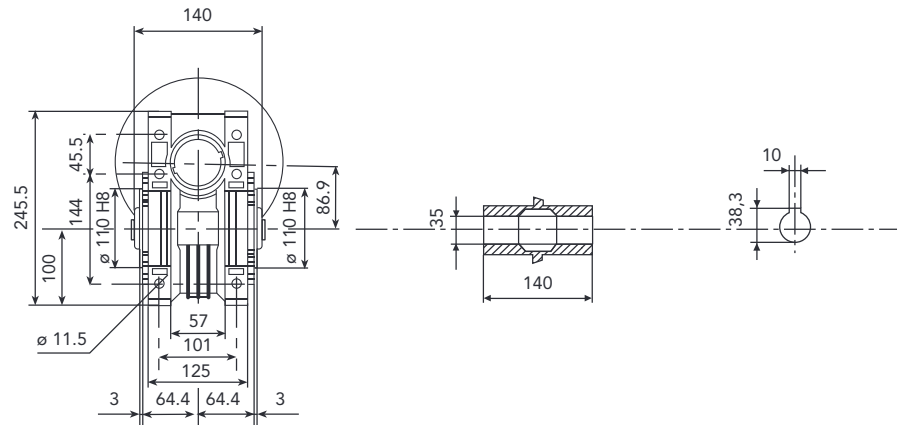
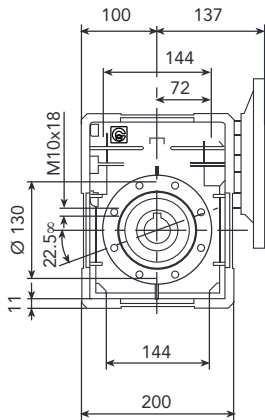

CH08FC 1

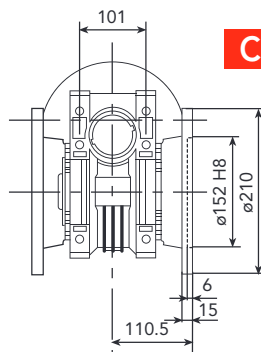

CH08FC 2

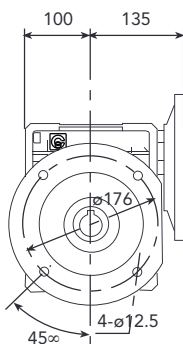

CH08F1

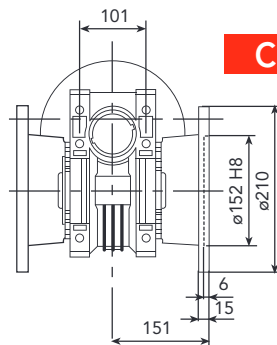

CH08F2